

## Comfort air conditioning unit with highly efficient regenerative heat storage packages

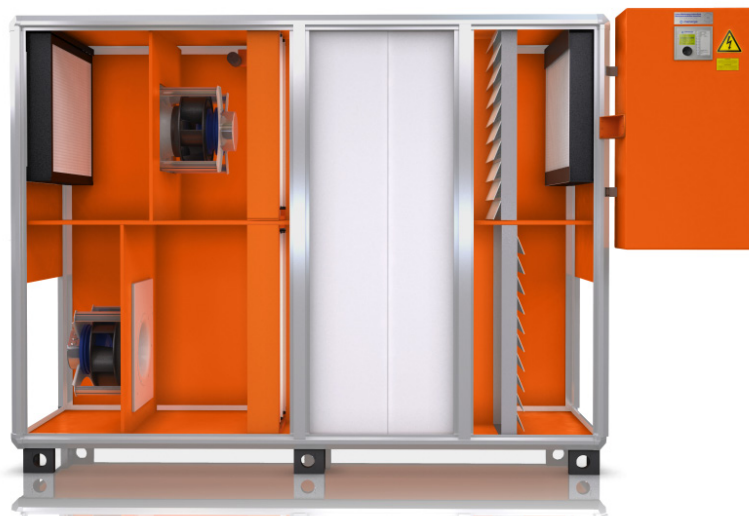

Resolair 62 26 01 - simplified illustration

Automatically selects the most economical operating mode!



Resolair

# Resolair 62 and 66

AIR VOLUME FLOW: 1,200 – 4,300 m<sup>3</sup>/h



### At a glance:

- ▶ For heat and cooling recovery
- ▶ Over 90% temperature efficiency
- ▶ Energy efficiency class H1 according to EN 13053:2012
- ▶ Corrosion-free heat storage packages made from polypropylene for more compact and lighter units
- ▶ Energy-saving EC fans
- ▶ Integrated compressor refrigeration system (66 series)
- ▶ Compact design
- ▶ Humidity recovery up to 70%
- ▶ Integrated control and regulation system, compatible with all conventional building management systems
- ▶ Fulfills the requirements of VDI 6022

Units of the Resolair 62 and 66 series achieve a very high heat recovery efficiency up to 90% and at the same time a moisture recovery up to 70% thanks to the regenerative heat recovery

system. The result is a comfortable climate at lowest energy costs. The integrated compression refrigeration system of Series 66 increases the cooling capacity of the entire system at high temperatures.

### Further performance parameters and options:

- Filtering the air in any operating mode
  - Cycle time adjustment for by-passing the heat recovery up to free cooling
  - Individually controllable performance parameters
  - Complete unit, ready to connect, contains all structural elements for comfort air conditioning, including all control and regulation fittings
  - Intensive quality inspection with factory test run
- Options
- Recirculation air heating damper
  - Pumped hot water heating coil
  - Pumped chilled water cooling coil (62 series)
  - Reversible compressor refrigeration system (66 series)
  - Outdoor installation
  - Thermal bridge factor TB1
  - Remote maintenance
  - And many more

## Functional description

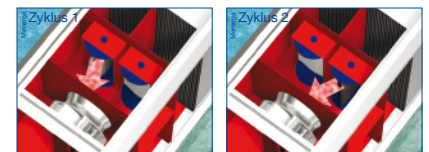
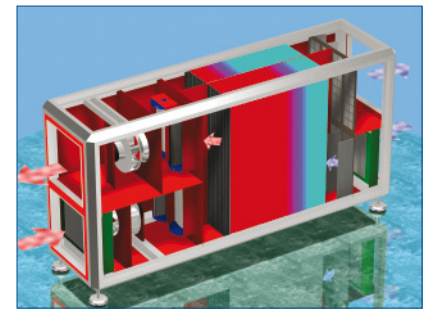
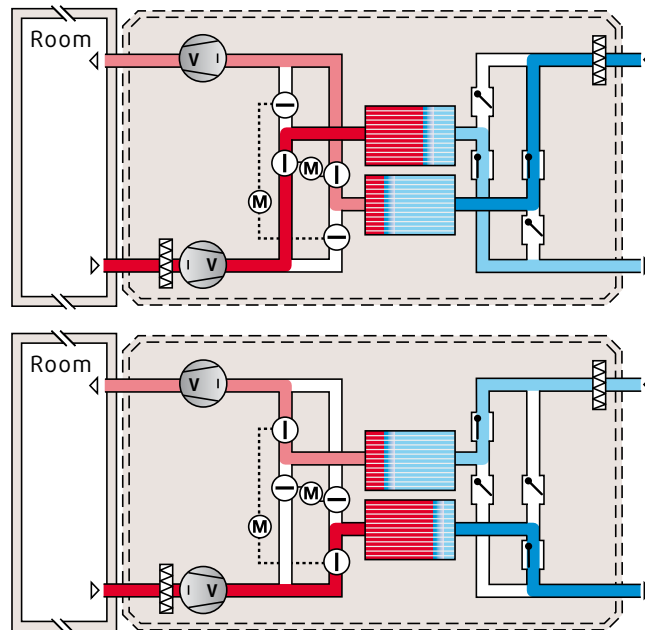

Resolair

The unit contains two heat storage packets with highly sensitive accumulator mass, through which the outside and return air are transported alternately. The accumulator mass is able to capture heat from a warm air flow very rapidly and transferring this just as rapidly to the cold air flow.

There is a damper system installed upstream and downstream of the packets. The damper system at RA/SA side is actuated by electric motors, while the damper system at OA/EA side operates dynamically.

The fans in the return air and supply air sections simultaneously supply cold outside air through one packet and warm return air through the other. One packet stores the heat from the return air, which the other packet simultaneously discharges

stored heat into the outside air. The temperature efficiency of the regenerative energy exchanger is over 90%. Thus the unit obtains virtually all the heat energy back from the return air. This means that an additional supply air heating coil is not needed and the internal heat load covers the transmission heat loss. Despite the very high heat recovery efficiency of the Resolair series, the regenerative heat recovery system used requires no defrost mode. The heating capacity normally needed is not required in this case.

In wintertime conditions, the humidity recovery of the regenerative heat recovery system is up to 70%, which in most applications makes an additional humidification system obsolete in winter.

Where outside air temperatures are rising, variable alteration of the switching cycles allows heat recovery to be reduced all the way down to free cooling.

If the outside temperatures exceed the indoor temperature, the unit switches back into the basic cycle and then operates in "cooling recovery mode" with the same high degree of efficiency as for heat recovery.

For the removal of higher internal heat loads at high outside air temperatures the integrated compressor refrigeration system is switched on.

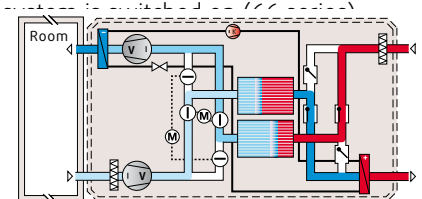

# Resolair Type 62

## System dimensions and weights

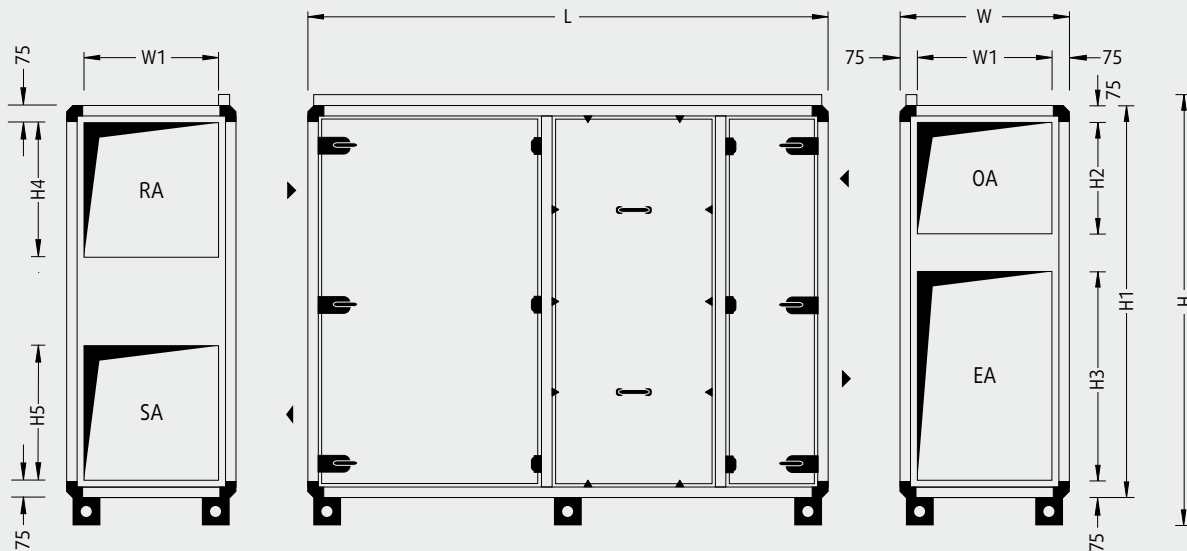

**Important!** Where a system is operated in parallel, the supply air and return air ducts of the two units have to be brought together.

Where units are run in parallel, each unit has a controls cabinet.  
Mirror-image design possible.

Unit feet 100 mm  
Optional: adjustable feet from 100 to 120 mm

Unit Type	L <sup>1</sup>	W <sup>2</sup>	H <sup>3</sup>	W1	H1	H2	H3	H4	H5	Weight <sup>1</sup>
62 12 01	2,010	570	1,210*	420	1,050	325	420	325	420	410
62 18 01	2,170	730	1,530*	580	1,370	485	580	485	580	550
62 26 01	2,330	730	1,850	580	1,690	485	900	580	580	600
62 36 01	2,330	1,050	1,850	900	1,690	485	900	580	580	810

## Controls cabinet

Unit Type	H x W x D <sup>1</sup>	Position at unit
62 12 01	480 x 640 x 210	on top of unit
62 18 01	480 x 640 x 210	on top of unit
62 26 01	900 x 480 x 210	OA/EA side
62 36 01	900 x 480 x 210	OA/EA side

For service work, a clearance corresponding to dimension W is required on the operating side of the unit. If dimension W is smaller than one metre, please leave a clearance of one metre. For service work above the unit, please allow 50 mm working height clearance above the cable duct.

Please comply with the dimensions for body size, air duct connections and electrical switch cabinet.

Partitioning of unit for smaller apertures possible (at extra cost).

All lengths are given in mm, weights in kg, weight incl. controls cabinet.

<sup>1</sup> May change depending on chosen option

<sup>1</sup> Door fitting assembly increase unit width by 25 mm each operating side

<sup>2</sup> Height incl. 100 mm unit feet and 60 mm cable duct

\* Controls cabinet arranged on top of unit, please add controls cabinet height (480 mm).

## Technical specifications and services

Unit Type		62 12 01	62 18 01	62 26 01	62 36 01
Optimum flow rate	m <sup>3</sup> /h	1,200	1,800	2,600	3,600
Max, volume flow rate <sup>1</sup>	m <sup>3</sup> /h	1,400	2,100	3,100	4,300
"Cooling recovery system" <sup>2</sup>	kW	2.0	3.0	4.3	6.1
Coefficient of power efficiency according to EN 13053:2012	%	90	90	90	90
Heat recovery rate according to EN 308	%	91	91	91	91
Recovery of humidity	%	up to 70			
Total electrical power rating <sup>3</sup>	kW	0.75	1.09	1.56	1.96
Max. current consumption <sup>3</sup>	A	6.6	13.8	8.0	6.6
Operating voltage		1 / N / PE 230 V 50 Hz		3 / N / PE 400 V 50 Hz	
<b>Ext, pressure loss</b>					
Supply and fresh air channel	Pa	300	300	300	300
Return and exhaust air channel	Pa	300	300	300	300
<b>Sound power level <sup>4</sup></b>					
Supply air vent	dB(A)	66	65	67	67
RA connection	dB(A)	63	60	61	60
Outside air vent	dB(A)	56	53	54	53
EA connection	dB(A)	58	58	60	60
Acoustic pressure at a distance of 1 m from the device <sup>4</sup>	dB(A)	47	46	48	48
<b>Fan units</b>					
Rated fan input for supply air <sup>5</sup>	kW	0.37	0.54	0.77	0.97
Rated fan input for return air <sup>5</sup>	kW	0.38	0.55	0.79	0.99
SFP category supply air   return air		2   2	2   2	2   2	2   2
Nominal rating supply air   return air	kW	0.8   0.8	1.4   1.4	2.5   2.5	2.0   2.0
Inner specific fan power (SFP <sub>int</sub> ) <sup>6</sup>	Ws/m <sup>3</sup>	851	747	886	689
<b>Efficiency classes according to EN 13053:2012</b>					
Heat recovery class		H1	H1	H1	H1
Power consumption of fans SA   RA		P1   P1	P1   P1	P1   P1	P1   P1
Air velocity class		V1	V1	V1	V1
<b>Filtration according to DIN EN 779</b>					
Outside air				F7	
Return Air				F7	
<b>LPHW (optional) <sup>7,8</sup></b>					
Heating capacity SA=22° C	kW	0.9	1.4	2.0	3.0
Heating capacity SA=30° C	kW	4.1	6.3	9.1	12.7
Additional power consumption for supply air	W	20	20	50	50
<b>Water flow rate and pressure losses at SA = 22° C</b>					
LPHW	m <sup>3</sup> /h   kPa	0.25   5.5	0.50   5.3	0.50   5.4	0.50   7.3
LPHW (pump warm water) valve	m <sup>3</sup> /h   kPa	0.10   6.8	0.16   6.2	0.24   5.7	0.29   8.6
<b>Connections</b>					
LPHW connection	DN	32	32	32	32
LPHW control valve connection	DN	10	10	10	10
<b>LPCW (optional) <sup>7,9</sup></b>					
Cooling capacity SA ≈ 20° C <sup>2</sup>	kW	4.6	6.7	9.1	16.4
Additional power consumption for supply air <sup>5</sup>	W	70	40	110	120
<b>Water flow rate and pressure losses</b>					
LPCW	m <sup>3</sup> /h   kPa	0.65   4.7	0.95   1.6	1.31   2.8	2.35   9.6
LPCW valve	m <sup>3</sup> /h   kPa	0.65   6.8	0.95   14.6	1.31   6.8	2.35   13.9
<b>Connections</b>					
LPCW connection	DN	32	32	32	32
LPCW control valve-connection	DN	15	20	25	25

Specifications of technical data relate to the optimum flow rate and return air condition 22° C / 40% r.h., outside air condition -12° C / 90% r.h. and standard density (1.204 kg/m<sup>3</sup>), unless otherwise specified.

- 1 May require alteration of the technical equipment
- 2 at OA = 26° C / 55% r.h., RA = 32° C / 40% r.h. and standard density

- 3 Depends on configuration of measurement and control system/unit
- 4 at 250 Hz mid-band frequency
- 5 with average filter contamination
- 6 According EU guideline No. 1253/2014 [Ecodesign guideline]
- 7 Supplementary equipment, device length extend at least 410 mm. Note higher power consumption of SA fan units

- 8 FL = 70° C
- 9 FL = 6° C

Please seek approval of technical data and specifications prior to start of the planning process. With every single selection we do to your individual requirements our certified selection software automatically checks the Ecodesign compliance level 1 and 2.

# Resolair Type 66

## System dimensions and weights

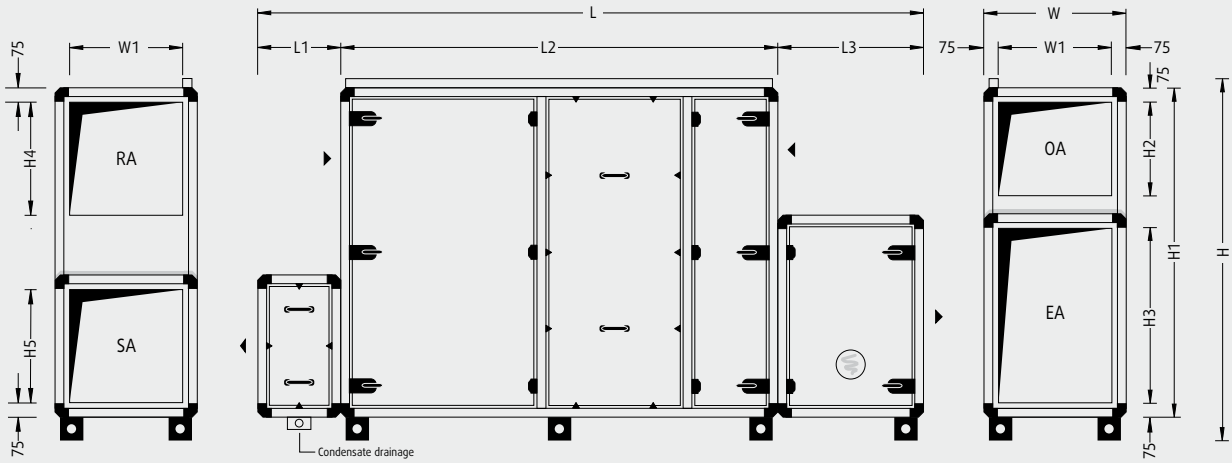

**Important!** Where a system is operated in parallel, the supply air and return air ducts of the two units have to be brought together.

Where units are run in parallel, each unit has a controls cabinet.

Mirror-image design possible

Unit feet 100 mm  
Optional: adjustable feet from 100 to 120 mm

Resolair

Unit Type	L <sup>1</sup>	W <sup>2</sup>	H <sup>3</sup>	L1	L2	L3	W1	H1	H2	H3	H4	H5	Weight <sup>1</sup>
66 18 01	3,310	730	1,530	410	2,170	730	580	1,370	485	580	485	580	790
66 26 01	3,470	730	1,850	410	2,330	730	580	1,690	485	900	580	580	850
66 36 01	3,470	1,050	1,850	410	2,330	730	900	1,690	485	900	580	580	1,100

## Controls cabinet

Unit Type	H x W x D <sup>1</sup>	Position
66 18 01	1,120 x 640 x 210	Wall mouniting
66 26 01	1,120 x 640 x 210	Wall mouniting
66 36 01	1,120 x 640 x 210	Wall mouniting

For service work, a clearance corresponding to dimension W is required on the operating side of the unit. If dimension W is smaller than one metre, please leave a clearance of one metre. For service work above the unit, please allow 50 mm working height clearance above the cable duct.

Please comply with the dimensions for body size, air duct connections and electrical switch cabinet.

Partitioning of unit for smaller apertures possible (at extra cost).

All lengths are given in mm, weights in kg, weight incl. controls cabinet.

- 1 May change depending on chosen option
- 2 Door fitting assembly increase unit width by 25 mm each operating side.  
Refrigerant pipe duct on backside of the unit increases unit width by 80 mm.
- 3 Height incl. 100 mm unit feet and 60 mm cable duct

## Technical specifications and services

Unit Type		66 18 01	66 26 01	66 36 01
Optimum flow rate	m <sup>3</sup> /h	1,800	2,600	3,600
Max. volume flow rate <sup>1</sup>	m <sup>3</sup> /h	2,100	3,100	4,300
"Cooling recovery system" <sup>2</sup>	kW	3.0	4.3	6.1
Coefficient of power efficiency according to EN 13053:2012	%	90	90	90
Heat recovery rate according to EN 308	%	91	91	91
Recovery of humidity	%	up to 70		
Total electrical power rating <sup>3</sup>	kW	3.8	5.9	7.6
Max. current consumption <sup>3</sup>	A	20.8	18.0	21.6
Operating voltage		3 / N / PE 400 V 50 Hz		
<b>Ext. pressure loss</b>				
Supply and fresh air channel	Pa	300	300	300
Return and exhaust air channel	Pa	300	300	300
<b>Sound power level <sup>4</sup></b>				
Supply air vent	dB(A)	64	66	65
RA connection	dB(A)	61	62	61
Outside air vent	dB(A)	55	57	55
EA connection	dB(A)	59	60	60
Acoustic pressure at distance of 1 m from device <sup>4</sup>	dB(A)	47	50	49
<b>Fan units</b>				
Rated fan input for supply air <sup>5</sup>	kW	0.59	0.88	1.08
Rated fan input for return air <sup>5</sup>	kW	0.57	0.82	1.02
SFP category supply air   return air		2   2	3   2	2   2
Nominal rating supply air   return air	kW	1.4   1.4	2.5   2.5	2.0   2.0
Inner specific fan power (SFP <sub>int</sub> )	Ws/m <sup>3</sup>	747	884	690
<b>Compressor refrigeration system <sup>2,7</sup></b>				
Filling volume for refrigerant type R410A	kg	3.0	3.0	4.0
Rated compressor input	kW	2.6	4.2	5.5
Mechanical cooling capacity	kW	8.6	12.7	17.7
Energy Efficiency Ratio <sup>8</sup>	EER	4.5	4.0	4.3
<b>Efficiency classes according to EN 13053:2012</b>				
Heat recovery class		H1	H1	H1
Power consumption of fans SA   RA		P1   P1	P1   P1	P1   P1
Air velocity class		V1	V1	V1
<b>Filtration according to DIN EN 779</b>				
Outside air			F7	
Return Air			F7	
<b>LPHW (optional) <sup>9,10</sup></b>				
Heating capacity SA=22° C	kW	1.3	2.0	2.9
Heating capacity SA=30° C	kW	6.2	9.0	12.7
Additional power consumption supply air	W	20	50	50
<b>Water flow rate and pressure losses at SA = 22° C</b>				
LPHW	m <sup>3</sup> /h   kPa	0.50   5.4	0.50   5.3	0.50   7.2
LPHW (pump warm water) valve	m <sup>3</sup> /h   kPa	0.16   6.1	0.24   5.6	0.29   8.6
<b>Connections</b>				
LPHW connection	DN	32	32	32
LPHW control valve connection	DN	10	10	10

Specifications of technical data relate to the optimum flow rate and return air condition 22° C / 40% r.h., outside air condition -12° C / 90% r.h. and standard density (1.204 kg/m<sup>3</sup>), unless otherwise specified.

- May require alteration of the technical equipment
- at OA = 26° C / 55% r.h., RA = 32° C / 40% r.h. and standard density
- Depends on configuration of measurement and control system/unit

- at 250 Hz mid-band frequency
- with average filter contamination
- According EU guideline No. 1253/2014 [Ecodesign guideline]
- SA = 17° C

- Incl. „cooling recovery“
- Supplementary equipment, device length extend at least 320 mm. Note higher power consumption of SA fan units
- FL = 70° C

Please seek approval of technical data and specifications prior to start of the planning process. With every single selection we do to your individual requirements our certified selection software automatically checks the Ecodesign compliance level 1 and 2.